

Sole Manufacturer and Distributor in the Czech Republic:
ATEC v.o.s.
Location of factory: ATEC v.o.s., Opolanská 350, 289 07 Libice nad Cidlinou
Czech Republic

ATEC 212 SOLO

ROTAX 912 UL

Flight and Operations Manual

Libice nad Cidlinou January 2007

Type of aeroplane

ATEC 212 SOLO

Serial number

.....

Identification label

.....

LAA CR type licence

..... issued

This aircraft is not registered at the state office and is to be operated at operator's own responsibility

The aeroplane must be operated according to the information and limits of this flight manual. This manual must ever be on the board of aeroplane

This manual must be at all times be carried on board of the aircraft

Contents	Chapter
General	1
Operational Limits	2
Emergency Instructions	3
Standard Procedures	4
Specifications	5
Assembly, Disassembly	6
Description of Aircraft and its Systems	7
Maintenance	8
Weight, Centre of Gravity	9

Chapter 1

1. General

1.1. Introduction

1.2. Personal Data of the Owner

1.3. Description of the Aeroplane

1.4. Completing of the Manual, Changes

1.5. Specification

1.6. Three-View Sketch

1.1. Introduction

The information provided by this manual is necessary for an effective and save operation of the **ATEC 212 SOLO** aircraft. Also included are information and documents of importance from the manufacturer.

1.2. Personal data of the owner

Owner of aircraft:

Address:

Telephone No:

Date from to:

Owner of aircraft:

Address:

Telephone No:

Date from to:

Owner of aircraft:

Address:

Telephone No:

Date from to:

1.3. Description of the Aeroplane

ATEC 212 SOLO is an ultralight single-seater cantilever low-wing aircraft of an all carbon composite construction. It is equipped with a tail landing gear with the steerable tail wheel. The power plant is a pull arrangement and consists of a ROTAX 912 UL 80 HP engine and a two-blade or three-blade fix or ground adjustable propeller FITI.

1.4. Specification

Dimensions

Wing span	7,48 m
Length of fuselage	5,2 m
Total height	1,4 m
Wing area	7,27 m ²
Depth of mean aerodynamic chord	1,032 m
Span of horizontal tail surface	2,18 m
Flap position	I 10°
	II 20°
	III 35°

Airfoil Section

Root section	SM 701
End section	SM 701

Tail Wheel Landing Gear

Wheel spacing	1,56 m
Wheel base	3,66 m
Tyre dimensions	350 * 120
Tyre pressure	0,16 MPa / 1,6 atp
Springing system	
Main wheels	composite spring
Tail wheel	composite spring

Brakes

Main wheels hydraulic disc brakes

Rescue System installed / not installed..... GRS 6/360

Weights

Empty weight	kg
Maximum take-off weight	300 kg
Maximum take-off weight including rescue system installed ...	315 kg
Maximum weight of luggage in luggage space ...	5 kg

Driving Unit

Propeller manufacturer	Josef Faturik
Type of propeller	FITI ECO COMPETITION 2 blade, 3-blade
Engine manufacturer	Bombardier – ROTAX GmbH
Type of engine	ROTAX 912 UL 80 HP

Power

Take-off power	59,6 kW / 80 HP / 5800 RPM
Maximum continuous power	58 kW / 78 HP / 5500 RPM
Cruising power	37,7 kW / 51 HP / 4800 RPM

Engine Speed

Maximum take-off engine speed	5800 RPM / 5 minutes maximum
Max. continuous engine speed	5500 RPM
Cruising engine speed	4800 RPM
Idling	1400 RPM approximately

Oil Temperature

Minimum	60°C
Operational optimum	90 - 110°C
Maximum	140°C

Temperature of Engine Cylinders

Minimum	60°C
Maximum	150°C

Oil Pressure

Minimum	0,8 bar
Operational	2,0 – 2,5 bar (over 3500 RPM)
Maximum short time operated by cold start	7,0 bar

Fuel Pressure

Maximum	0,4 bar
Minimum	0,2 bar

Operational Temperature

Maximum	50°C
Minimum	-25°C

Fuel Type See Art. 2.9.

Oil Type

Any branded oil for 4 stroke motorcycle engines with gearbox additives. Power class SF, SG + GL4 or GL5.

ROTAX 912 UL is not certificate as an aircraft engine and a failure may occur whenever. The pilot is fully responsible for consequence of engine failure

1.6. Three-View Sketch

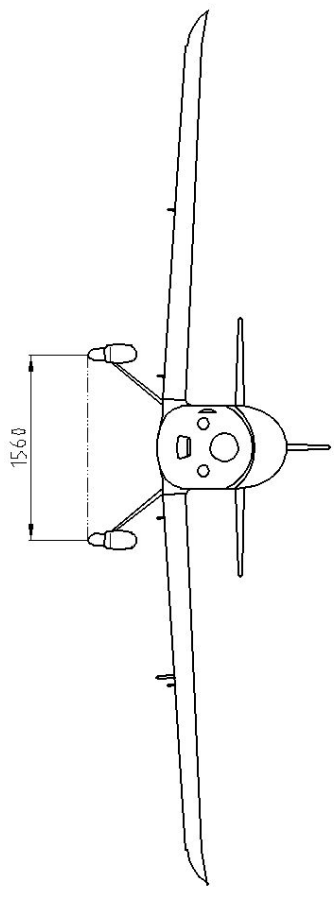
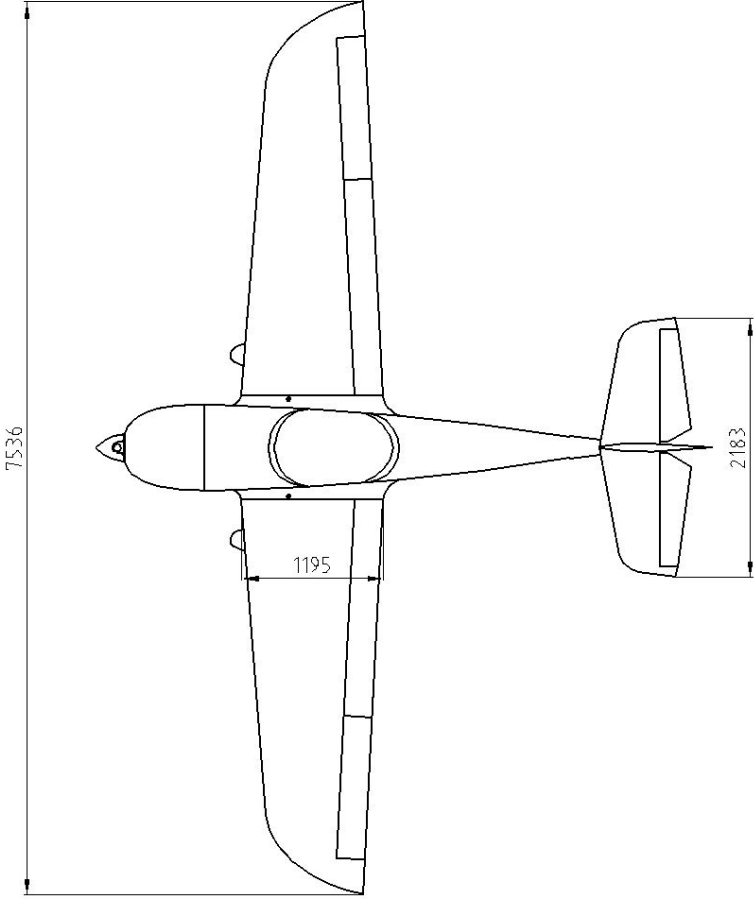
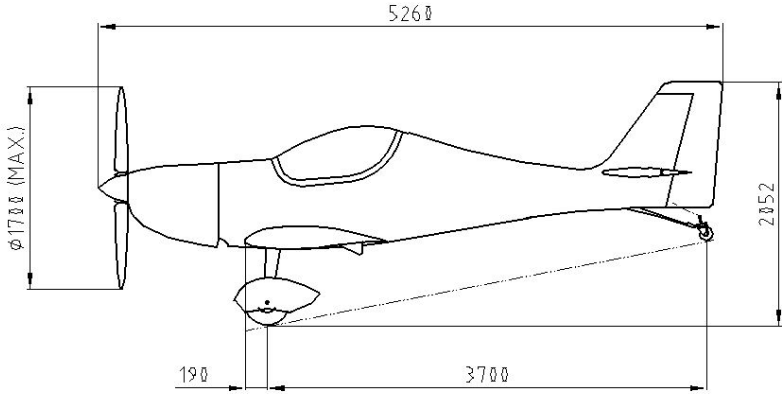

Chapter 2

2. Operational Limits

2.1. Introduction

2.2. Air Speeds

2.3. Weights

2.4. Centre of Gravity

2.5. Manoeuvre and Gust Envelope

2.6. Permitted Manoeuvres

2.7. Operational Load Factors

2.8. Type of Operation

2.9. Crew

2.10. Fuel

2.11. Wind

2.12. Other Limits

2.1. Introduction

The chapter 2 contents are operational limits necessary for a safe operation of the aircraft

2.2. Air Speeds

Never exceed speed V_{NE} 286 km/h 154 kt

Do not exceed this speed in any case

Design manoeuvre speed V_A 187 km/h 101 kt

Do not use full deflection of the rudders and sudden control operations. Overload of the aircraft may occur

Maximum design cruising speed V_C 238 km/h 128 kt

Operation over this speed must be conducted with caution in smooth air only

Maximum speed at flaps deflection 10° V_{FI} 140 km/h 75 kt

Maximum speed at flaps deflection 20° V_{FII} 130 km/h 70 kt

Maximum speed at full deflection 35° V_{FE} 120 km/h 65 kt

Maximum recommended speed at def. 35° V_{FIII} 100 km/h 55 kt

Do not exceed this speed by flaps deflected

Stalling speed flaps retracted V_{SI} 76,4 km/h 41 kt

The loss of uplift and fall of aircraft with flaps retracted happens by this speed

Stalling speed in landing configuration V_{SO} 64,2 km/h 35 kt

The loss of uplift and fall of aircraft with flaps position III deflected happens by this speed

2.3. Weights

Empty weight kg

Maximum take-off weight 300 315 kg

Useful load kg

Never exceed the maximum take-off weight of the aeroplane

2.4. Centre of Gravity (CG)

CG of the empty aeroplane % MAC

Flight range of CG 28 – 36% MAC

2.5. Manoeuvre and Gust Envelope

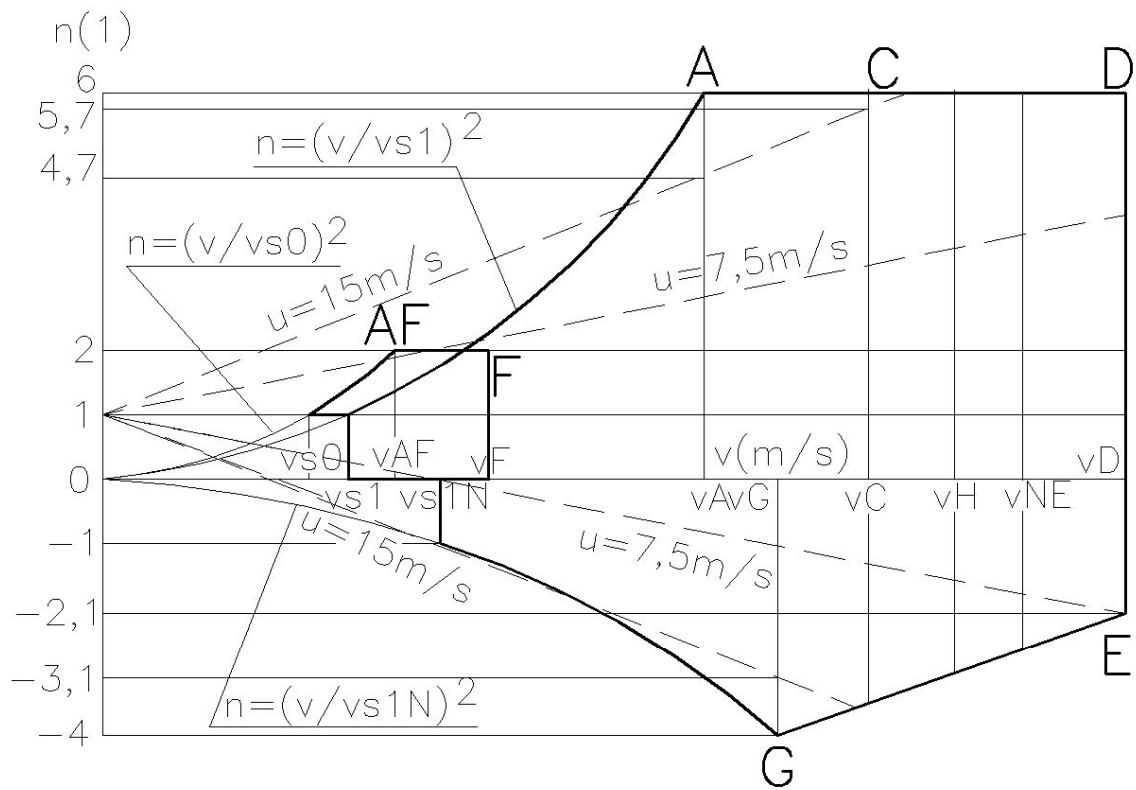

v_{S0}	=	64,2	km/h	=	17,8	m/s	=	34,8	kt
v_{S1}	=	76,4	km/h	=	21,2	m/s	=	42,9	kt
v_{AF}	=	90,8	km/h	=	25,2	m/s	=	49,0	kt
v_{S1N}	=	105	km/h	=	29,2	m/s	=	56,7	kt
v_F	=	120	km/h	=	33,3	m/s	=	64,8	kt
v_G	=	210	km/h	=	58,3	m/s	=	113	kt
v_A	=	187	km/h	=	52,0	m/s	=	101	kt
v_C	=	238	km/h	=	66,3	m/s	=	128	kt
v_H	=	265	km/h	=	73,6	m/s	=	143	kt
v_{NE}	=	286	km/h	=	79,5	m/s	=	155	kt
v_D	=	318	km/h	=	88,3	m/s	=	172	kt

2.6. Permitted Manoeuvres

Category of the aeroplane: Normal

Except of the normal flight manoeuvres, the sharp turns up to bank of 60°, level and climbing turns are permitted.

Acrobatics, intended spins and stalls are prohibited

2.7. Operational Load Factors

Maximum positive load factor in CG	+6,0 g
Maximum negative load factor in CG	-4,0 g

2.8. Type of operation

Permitted day flights VFR only (flights by unobstructed field of vision)

IFR flights (instrument flights) and flights by ice formation are prohibited

2.9. Crew

Number of seats	1	
Minimum weight of crew	65 kg	see Art. 9.4.
Maximum weight of crew	90 kg	see Art. 9.4.

2.10. Fuel

Recommended motor fuel unleaded petrol with oil. Minimum octane number of petrol 95.

Oil / Fuel mixture 1 : 50.

Fuel capacity	49 l
Not usable rest of fuel	0,7 l

2.11. Wind

The safe taking off and landing is possible if the following wind speed limits are not exceeded:

- | | | | |
|----|------------------------------------|-------|--------------|
| a) | taking off or landing against wind | | up to 12 m/s |
| b) | taking off or landing tail wind | | up to 3 m/s |
| c) | taking off or landing cross wind | | up to 3 m/s |

2.12. Other limits

Smoking and using of mobile telephones is prohibited in the aircraft.
Transportation of explosives and free loaded objects is prohibited.

Chapter 3

3. Emergency Instructions

3.1. Engine Failure Taking-Off

3.2. Engine Failure in Flight

3.3. Rescue System Application

3.4. Fire in Flight

3.5. Power-Off Flight

3.6. Emergency Landing

3.7. Safety Landing

3.8. Aborted landing

3.9. Vibration

3.1. Engine Failure on Take-Off

1. **Push stick forward aircraft into gliding attitude and maintain airspeed of 100 km/h (54 kt).**
2. Determine the wind direction, adjust flaps for suitable position, turn off fuel valve, switch-off ignition, adjust safety belts and switch-off the master switch just before landing.
- A. At a height up to 50 m get the aircraft into landing configuration and carry out a landing with respect for obstructions in take-off direction.
- B. At a height above 50 m choose a suitable area for emergency landing.

3.2. Engine Failure in Flight

1. **Get the aircraft into gliding attitude and maintain airspeed of 100 km/h (54 kt).**
2. Check a fuel level, switch on and make sure ignition is switched on.
3. If no problem found, try restarting the engine once more using additional fuel system.
4. If restarting impossible, use the instructions 3.1.

3.3. Rescue system deployment

In distress by final loss of flight control do activate the rescue system

1. Switch off ignition
2. Adjust safety belts
3. Activate the rescue system

In case of landing on a limited area when collision is inevitable, use the rescue system for a braking devise.

The aircraft can be damaged or the crew may be injured due to using a rescue system
--

3.4. Fire in flight

1. Close the fuel valve
2. Open the throttle
3. Switch off the main switch and ignition
4. Do emergency landing
5. Get off the aircraft

3.5. Power-off flight

1. Speed 100 km/h 54 kt
3. Flaps retracted
4. Normal flight conditions

3.6. Emergency landing

1. Carried out in case of engine failure
2. Speed 100 km/h 54 kt
3. Adjust safety belts
4. Flaps according to situation
5. Announce the situation by the aeroplane radio station
6. Close the fuel valve
7. Turn off ignition
8. Turn off the main switch

In case of emergency landing onto a terrain and surfaces non-approved for light aircraft landings an aircraft damage and crew injury may occur

3.7. Precautionary landing

Carry out in case of the loss of orientation, fuel exhaustion or for other reason if the aircraft is fully controllable.

1. Determine the wind direction
2. Choose a suitable landing area
3. Carry out a low pass into the wind along the right-hand side of landing area and inspect the area thoroughly.
4. Carry out a circuit flight
5. Calculate the landing plan
6. Land in the first third of the landing area using landing flaps

3.8. Aborted landing

Carry out in case of wrong calculation of landing manoeuvre or after jump out by landing in case of pilot's consideration to abort landing manoeuvre and continue to fly.

1. Set up engine speed on maximum power
2. Set up take-off flaps position – I
3. Get level speed 110 km/h 59 kt
4. Draw up control stick slowly to get aircraft into climbing at speed 140 km/h 75 kt
5. Retract flaps at an air speed 120 km/h 76 kt
- 6.

Keep runway direction all the take off time using rudder

3.9. Vibrations

In case of unusual vibrations occurs.

1. Set the engine speed to where vibration is least
2. Carry out the safety landing checks for a possible emergency landing and head for the nearest airport

Chapter 4

4. Standard Procedures

4.1 Pre-Flight Inspection

4.1.1 Procedures Before Entering the Cockpit

4.1.2 Procedures After Entering the Cockpit

4.2 Procedures Before Starting the Engine and Starting the Engine

4.3 Warming up the Engine, Engine Check

4.4 Taxiing

4.5 Pre Take-Off

4.6 Take-Off and Climb Away

4.7 Cruising Flight

4.8 Descend and Landing

4.9 Flight in the Rain

4.1. Pre-Flight Inspection

It is important to carry out a proper pre-flight inspection failure to do so or perform an incomplete inspection could be the cause of an accident. The manufacturer recommends using the following procedure:

4.1.1. Procedures Before Entering the Cockpit

1. Check ignition - turned off.
2. Check main switch – turned off
3. Check the wings, wing surfaces ailerons and flaps, clearances, hinges and connections of the controls, security of the wing pins, Pitot tube.
4. Check the tail surfaces, elevator and rudder for secure connections, clearances and free movement.
5. Check the fuselage, the surface and state.
6. Check the landing gear, laminate springs, security of main and front wheels, their covers, screws and nuts, proper tire pressure, break function.
7. Engine – the state of fastening of the engine covers, the state of the engine bed, intact fuel, oil and cooling system hoses, the fuel system drain.
8. Propeller – the surface state, if it is intact, the state and fastening of the propeller cone.
9. Canopy – control of fastening and proper locking of the canopy, correct functioning and condition of the electrical installation of instruments, the state of the flight instruments, control of the fuel level, proper functioning of controls.

Before entering the cockpit step on the marked foot-path on the wing only. Stepping outside the marked area especially on the flap may damage the airframe seriously

4.1.2 Procedures After Entering the Cockpit

1. Check foot-operated controls
2. Check brakes – brakes on
3. Check hand - operated controls
4. Check flaps
5. Check engine controls
6. Check fuel valve
7. Check fuel level indicator
8. Check main switch – turned off
9. Check ignition – turned off
10. Check instruments – state, zero positions, adjust altimeter

4.2. Procedures Before Starting the Engine and Starting the Engine

1. Rescue system - unlock
2. Safety belts - fasten
3. Close the canopy and secure
4. Turn on the fuel valve

5. Throttle to idle run
6. Open the choke if the engine is cold
7. Pull up the control stick
8. Main switch on
9. Ignition on
10. Brakes on
11. Start the engine
12. Turn off the choke
13. Warm up the engine until the operating temperature

4.3. Warming up the Engine

Start to warm up the engine at 2000 rpm, hold approx. 2 minutes, continue until 2500 rpm till the oil temperature reaches 50°C. Check both ignition circuits according to Art. 4.5.

4.4. Taxiing

Recommended speed of taxiing is 15 km/h 8 kt max, direction is controlled by the tail wheel using pedals. Hand brake control is on the control stick. Control stick pulled up.

4.5. Pre Take-Off

Compulsory procedures prior take-off:

- | | | |
|-----|----------------------------------|---------|
| 1. | Brakes | checked |
| 2. | Foot-operated controls | checked |
| 3. | Hand operated controls | checked |
| 4. | Flap position I set and | checked |
| 5. | Choke turned off | checked |
| 6. | Fuel master switch on and | checked |
| 7. | Fuel gauge indicator | checked |
| 8. | Instruments on and within limits | checked |
| 9. | Safety belts secure | checked |
| 10. | Cockpit secure and locked | checked |

4.6. Take – Off and Climb Away

By accelerating until the maximum position of the throttle is reached, make the aeroplane move. Fly off the tail wheel pushing control stick and then get control back to neutral position. Keep the aeroplane running on the main wheels at a normal flight position in the axis of the runway using rudder and elevator control. At speed of 75 km/h ... 40 kt you make the aeroplane fly off the earth by a light pull of the stick and continue the flight until 110 km/h ... 59 kt Then by gradual pull you make the aeroplane start climbing at the optimum speed of 120 - 140 km/h ... 65 – 75 kt. Retract flaps after the height of 50 m ... 150 feet and a speed of 120 km/h ... 65 kt is reached. The marginal engine values must not be exceeded during the take-off.

4.8. Cruising flight

ATEC 212 SOLO has good flight features in the whole range of permitted speeds and centre of gravity positions. The cruising speed is in the range **120 – 243 km/h 65 – 131 kt.**

4.9. Descent and landing

Carry out the descent with the throttle in idle run at speed of 100 km/h 54 kt
Flaps position limitations according to Art. 2.2

Procedures in the final:

1. Speed 90 km/h 49 kt
2. Wing flaps in position III (at strong turbulence or headwind position II)
3. Throttle idle, or corrected if necessary
4. Instruments in the permitted limits

Landing

The aeroplane in the hold-up position decreases its speed by a gradual pull of the control stick until it touches down on the main wheels at speed of 70 km/h 38 kt. After the touch down of the tail wheel, the landing run can be cut down by breaking. Keep runway direction all the time using foot control. Keep the control stick pulled up by taxiing.

Do not apply a maximum brake effect except of an extreme situation. An undue wear of tyres, brake lining and disc comes to and an over-stress of undercarriage and other parts may shorten durability of an aircraft rapidly.

4.10. Flight in the rain

During the flight in the rain, the pilotage should be carried out with increased caution because of the decreased visibility and cockpit transparency. Furthermore, one should take into account a shortened hold-up position during the landing and extended take-off distance.

Maintain the following speeds during the flight in the rain:

- | | | | |
|-----------------------|----------------|-------|------------------------------------|
| 1. Climb away | 140 km/h | | 75 kt |
| 2. Cruising flight | 120 – 200 km/h | ... | 65 – 108 kt |
| 3. Descent at landing | 100 km/h | | 54 kt, flaps I or II, see Art. 2.2 |

Chapter 5

5. Performances

5.1. Introduction

5.2. Stalling Speeds

5.3. Take off Distance at 15 m / 50 ft Height

5.4. Rate of Climb

5.5. Cruising Speeds

5.6. Range of Flight

5.1. Introduction

The information in stalling speed and other performances of the ATEC 212 SOLO with ROTAX 912 UL 80 HP and propeller FITI ECO COMPETITION 2b/168.

5.2. Stalling Speeds (CAS)

Engine idling	Flaps retracted	Flaps I (10°)	Flaps II (20°)	Flaps III (35°)
	72 km/h ... 39 kt	65 km/h ... 35 kt	63 km/h ... 34 kt	62 km/h ... 33 kt
Engine stopped	75 km/h ... 40 kt	67 km/h ... 36 kt	65 km/h ... 35 kt	64 km/h ... 35 kt

5.3. Take off Distance at 15 m / 50 feet height

Runway surface	Take off distance
Concrete	190 m ... 620 ft
Turf	215 m ... 700 ft

5.4. Rate of Climb

Air speed	Rate of climb
120 km/h ... 65 kt	8,5 m/s ... 1700 FPM
140 km/h ... 75 kt	8 m/s ... 1600FPM

5.5. Cruising Speeds

ROTAX 912 UL 80 HP

Air speed (IAS)	RPM	Fuel consumption
120 km/h ... 64,8 kt	3000	4,8 l/h ... 1,26 USGPH
140 km/h ... 75,6 kt	3350	6,2 l/h ... 1,64 USGPH
160 km/h ... 86,4 kt	3650	8,0 l/h ... 2,11 USGPH
180 km/h ... 97,2 kt	3950	10,0 l/h ... 2,64 USGPH
200 km/h ... 108 kt	4270	12,2 l/h ... 3,22 USGPH
220 km/h ... 119 kt	4600	14,8 l/h ... 3,91 USGPH
240 km/h ... 130 kt	5020	17,8 l/h ... 4,70 USGPH
260 km/h ... 140 kt	5350	21,0 l/h5,55 USGPH
280 km/h150 kt	5600	24,5 l/h6.47 USGPH

5.6. Range of Flight

Air speed (IAS)	Range of flight	30 min. flight reserve
140 km/h ... 75,6 kt	1036 km ... 560 nm	3,11 ... 0,82 USG
160 km/h ... 86,4 kt	900 km ... 486 nm	4,01 ... 1,05 USG
180 km/h ... 97,2 kt	792 km ... 428 nm	5,01 ... 1,3 USG
200 km/h ... 108 kt	703 km ... 380 nm	6,11 ... 1,6 USG
220 km/h ... 119 kt	618 km ... 334 nm	7,41 ... 2,0 USG
240 km/h ... 130 kt	539 km ... 291 nm	8,91 ... 2,3 USG
260 km/h.....140,5 kt	476 km257 nm	10,512,77 USG

Chapter 6

6. Assembly and Dismantling

6.1. Introduction

6.2. Dismantling the Horizontal Tail Surface and the Rudder

6.3. Dismantling the Wings

6.4. Assembly

6.1. Introduction

The assembly of individual parts of the aeroplane is described in this chapter. At least two persons are necessary for the assembly and dismantling.

6.2. Dismantling the Horizontal and Vertical Rudder

The HT and VT stabilizers are an integral part of the fuselage

Dismantling VT rudder. Disconnect control. Release and unbolt the bolt M6 at the lower part of the rudder. Take out the rudder from the hinges moving it down and backwards.

Dismantling elevator. Release and remove elevator pins using suitable tongs. Take out elevator moving it backwards.

6.3. Dismantling the wings

Disconnect the pins of ailerons and flap control in the cabin space. Release and remove the lock nut of the M10 bolt of the wing pins. Screw the bolt off by about 20 mm. The helper lifts the wing a bit by holding it at the end. By light taps on the head of the bolt the bottom pin is knocked-out. Unscrew the bolt and remove the pin. Then the upper pin is driven out with the help of a rod with 18 mm diameter. After removed pins lift up the wing and disconnect the hoses of the static and total pressure. Those hoses must not be interchanged during assembly. Disconnect strobe-light or position light cables if the aircraft is equipped with them.

6.4. Assembly

The assembly is carried out in the opposite way. All pins must be cleaned and greased and then secured. Take care about the proper adjustment of ailerons, which is done by shortening and extending the aileron connection struts. Ever use new securing wire, new split pins and new self-locking nuts.

Chapter 7

7. Description of the Aeroplane and Its Systems

7.1. Wing

7.2. Fuselage

7.3. Tail Surfaces

7.4. The Landing Gear

7.5. Control

7.6. The Driving Unit

7.7. Fuel System

7.8. Instrument Equipment

7.9. The Sense of Motion of the Control Elements

7.1. Wing

The cantilever tapered wing with conventional ailerons, slotted flaps and wing-tips. The main spar of laminated beech wood saturated with synthetic resin at a high temperature is placed in the 30% depth of wing. The wing skin is made of carbon sandwich. The wing is reinforced by ribs of plastic and composites, the root ribs are of carbon – nomex honeycomb sandwich. Ailerons and flaps are of all composite construction. The centre-wing section is welded from high quality CrMo steel tubes.

7.2. Fuselage

The fuselage is an all-carbon composite shell reinforced by bulkheads. The fuselage cross-section is elliptic, with wing fillets and spacious cockpit. The cockpit enclosure is from organic glass and it is lifted up and to the right. The engine space in the front part of the fuselage is separated by a firewall. The engine bed is fastened to a fire-proof engine bulkhead.

7.3. Tail Surfaces

The conventional tail surfaces are of all carbon composite construction. The horizontal tail surface has a trapezoidal shape formed by a rigid stabiliser and elevator. The vertical tail surface and the rudder have a trapezoidal shape. The tail unit is an integral part of the fuselage.

7.4. The Landing Gear

The landing gear is a fixed two-wheel undercarriage with a controllable tail wheel. The main landing gear is formed by a pair of composite flat springs. Main wheels of dimensions 350 x 100 mm are covered by aerodynamic fairings and are equipped with disc brakes hydraulically controlled.

7.5. Control

The ailerons, elevator and the flaps are controlled with the help of pushrods and levers, the rudder with the help of steel wire ropes. Important check points have inspection openings overlapped by organic glass. No part of control system interferes exterior of the airframe.

7.6. The Driving Unit

The driving unit is the engine ROTAX 912 UL 80 HP and the two-blade ground adjustable propeller FITI ECO COMPETITION.

7.7. Fuel System

The fuel system is formed by an integral fuselage tank with a fuel drain. Double fuel supply circuit with a spare electric pump. The pressure of supplied fuel is measured with a fuel-pressure gauge. The fuel reserve 10 l at flight position is indicated by control light.

7.8. Instrument Equipment

The instrument equipment consists of basic instruments for flight control, engine control and navigation. The static and total pressure is taken from the Pitot tube at the bottom of the port wing.

7.9. The Sense of Motion of the Control Elements

Foot-operated control

By pressing the left pedal, the aeroplane turns left when moving at sufficient speed on the ground or in the air, and vice versa.

Hand-operated control

By pulling the control stick towards the pilot, the nose lifts up (the angle of incidence increases) and the aeroplane climbs. By pushing the control stick, the aeroplane descends. By deflecting the control stick to left, the aeroplane banks to left, and vice versa.

Wing flaps

By switching over the flap change-over switch to I, II, III or OFF position, the flaps are moved to corresponding deflection by electric actuator. Each position is indicated by LED control light.

The engine throttle

By moving the throttle in the flight direction, the engine power increases, and vice versa.

Choke

Choke lever backwards – the choke is turned on

Choke lever forwards – the choke is turned off

Chapter 8

8. Care and Maintenance

8.1. Maintenance Schedule

8.2. Aeroplane Repairs

8.3. Major Overhaul

8.4. Anchorage of the Aeroplane

8.5. Cleaning and Care

8.1. Maintenance Schedule

Inspection, Mandatory Work	Inspection Period				
	10	25	50	100	200
Engine					
As per ROTAX Manual attached.					
Engine Compartment					
Engine Attachment Check integrity of construction with special care for welds, fixing points, silent blocks, bushings. Surface finish quality.				X	
Bolted Connections Check surface quality of bolted connections and bearing surfaces. Securing, tightening. Tighten and re-secure if necessary, Replace self locking nuts, split pins and securing wires.			X		
Silent Blocks Check elasticity of engine bearing, integrity of rubber blocks, degree of permanent deformation. Replace silent blocks if necessary, tighten, secure.				X	
Oil, Water and Fuel Hoses Check surface integrity, liquid leakage, quality of connections, protection against oscillating parts and exhausts. Replace if necessary.		X			
Working Liquids Check level, refill keeping instruction of engine manufacturer.	X				
Coolers Check integrity, sealing, purity.				X	
Controls Check control forces, free play, hinges, end stops adjustment, self-locking. Adjust, secure.			X		
Exhausts Check integrity, sealing, corrosion degree, springs quality and prestress. Grease ball connections.				X	
Carburetors Check surface quality, controls adjustment, quality of elastic connection flange – integrity, sealing. Replace flange if material degradations or surface cracks appear.		X			
Electric Installations Check quality, integrity and purity if cables, contacts, welds, bunched cable supports and bushings. Check gauges and senders connections.					X
Propeller Attachment Check quality of bolts, tightening moments, securing.				X	
Cockpit					
Control Sticks Check free movement in longitudinal and cross direction, clearance fits, end stops adjustment, securing. Replace pins or bolts if worn-out, grease, secure.				X	
Rudder Control Check integrity of pedals with special care for surface cracks near welds. Full and free movement right and left (raise nose wheel off ground), end				X	

stops adjustment, rudder cable tensioning, clearance fits, securing. Adjust, replace worn-out parts, grease, secure.					
Flap Control Check free movement of flap control lever, stable bearing in every flap position, interlock pin wear. Replace worn-out parts, grease, secure.			x		
Canopy – Open / Close Check quality and function of locks and hinges, canopy bearing. Adjust, replace worn-out parts, grease, secure.					x
Flight Control Instruments Check legibility, markings, attachment instruments in panel, installations, wiring.					x
Electric Installations Check quality, integrity and purity of cables, insulations, contacts and welds. Battery attachment, working condition.					x
Safety Belts Check fixing points rigidity, belt surface quality, adjustment.				x	
Fuel System Check leak-proof condition, fuel supply quality, fuel pumps and valve function, tank de-aeration. Replace fuel filters.		x			
Parachute Rescue System Check general condition, attachment. Do mandatory work as per instructions of rescue system manufacturer.					x
Landing Gears					
Main Gear Check attachment rigidity, surface quality, degree of permanent deformation.			x		
Wheels Check attachment, brakes condition, brake pads, disc quality, leak-proof condition. Attachment and purity of wheel spats.		x			
Front Gear Check general condition, integrity, rubber damper, clearance, springing deflection, steering quality. Grease sliding bearings, replace rubber springs if worn-out.		x			
Fuselage Check general condition, integrity. Antennas, lights and coverings attachment.					x
Wing Check general condition, surface quality, integrity, attachment, fittings, clearance. Ailerons and flaps condition, surface quality, hinges, clearance, securing. Controls condition, free movement, end positions, clearance. Pitot tube condition and attachment.			x		
Tail Surfaces					
Rudder, Elevator Check general condition, hinges, movement, clearance, securing.					x
HT Stabilizer Check general condition, attachment, fittings, securing.				x	
	10	25	50	100	200

8.2. Aeroplane Repairs

The owner of aeroplane is obliged to report to the manufacturer each damage which may have an influence on an airframe strength or flight qualities. The manufacturer determines a way of repair.

Minor repairs are the repairs of those parts, which do not participate substantially in the aeroplane function and stiffness.

Among the permitted repairs are:

- the lacquer repair
- replacing the worn-out parts
- repairing the tyres of the landing wheels

These repairs can be carried out by the owner itself. Repairs of the torsion box, spars, wing or tail surfaces, landing gears and carrying load parts of airframe must be carried out in a special workshop. In case of surface finish repairs and changes the upper parts of aeroplane must always be kept in white.

8.3. Major Overhaul

The major overhaul is carried out after 1200 flight hours but not later than 10 years after putting the aeroplane into operation, unless decided otherwise during regular technical inspections or by the company bulletin. The overhaul will be carried out in a special workshop. The overhaul and maintenance are carried out according to the instructions of the engine producer.

8.4. Anchorage of the Aeroplane

The anchorage of the aeroplane is necessary in order to protect the aeroplane against eventual damage caused by the wind or wind blasts during parking outside the hangar. For the purpose, the aeroplane is equipped with threaded holes at the bottom side of the wing and at the tail skid. Threaded eye bars can be fastened into these points.

8.5. Cleaning and Care

The aeroplane surface should always be treated by using suitable cleaning agents. The oil and grease residues can be removed from the aeroplane surface by suitable surface active substances or eventually by petrol. The cockpit enclosure should be cleaned only by washing using a sufficient water flow with an addition of suitable surface active substances. Never use petrol or chemical solvents.

Chapter 9

9. Weight, Centre of Gravity

9.1. Introduction

9.2. Empty Weight

9.3. Maximum Take-Off Weight

9.4. CG Range

9.5. CG Determination

9.6. Useful Load, Weight Table

9.1. Introduction

The weight, useful weight and centre of gravity information is described in this chapter.

9.2. Empty Weight

The weight of aircraft full equipped, without fuel and pilot. It is weighed as a total weight of all wheels weights.

The empty weight of the **ATEC 212 SOLO** including ROTAX 912 UL 80 HP and standard equipment with / without rescue system is

..... kg

9.3. Maximum take-off weight

300 315 kg

Never exceed the maximum take-off weight

9.4. Centre of gravity range

The aircraft CG including the pilot of 75 kg without fuel is

32,6 % of MAC

The flight range of CG specified by manufacturer is

28 – 36% of MAC

Operation over this range is prohibited

9.5. Centre of gravity determination

The aircraft has to be weighed at flight position including pilot and fuel.

Weight on main wheels	G_1	(kg)
Weight on tail wheel	G_2	(kg)
Total weight	$G = G_1 + G_2$	(kg)
Wheel base	$x_{MW-TW} = 3,7$	(m)
Distance from main wheel centre to leading edge of wing in root point	$x_{MW-LE} = 0,19$	(m)
CG distance from main wheel centre	$x_{MW-CG} = G_2 * 3,7 / G$	(m)
Length of MAC	$b_{MAC} = 1,032$	(m)
Length of wing chord in the root area	$b = 1,19$	(m)
Back-swept MAC displacement	$s_y = 0,088$	(m)
CG distance from leading edge of wing in root point	$x_{LE-CG} = x_{MW-LE} + x_{MW-CG} =$ $= 0,19 + 3,7 * G_2 / G$	(m)
Distance from CG to leading edge of MAC	$x_{CG-MAC} = x_{LE-CG} - s_y =$ $= 0,102 + 3,7 * G_2 / G$	(m)
	$x_{CG-MAC\%} = x_{CG-MAC} * 100 / 1,032 =$ $= 9,884 + 358,5 * G_2 / G$	(%)

9.6. Useful weight, weight table

Useful weight is a difference between maximum take-off weight and the weight of empty aircraft.

The useful weight by empty weight kg is kg.

The weight table

Fuel tank 50 l 1 l = 0,775 kg	Pilot weight kg incl. 5 kg luggage	CG % MAC	Total weight of aircraft kg
1/4 12,5 l			
1/2 25,0 l			
3/4 37,5 l			
1 50,0 l			